



Teton Grill Company – 3880 Fourth Avenue East – Shakopee, Minnesota, 55379

**Stainless Steel Gas Grill  
Use and Care Guide  
Mode**



**WARNING:**

All barbecues and carts are designed for outdoor use only and cannot be installed in or on boats. This barbecue is not intended to be installed in or on recreational vehicles. All barbecues are not intended for commercial use.

**Owner:** Read this Owner's Manual carefully and be certain that your gas grill is properly assembled, installed and maintained. Failure to follow these instructions could result in serious bodily injury and/or property damage.

**Note to Installer:** Leave this Owner's Manual with the consumer after delivery and/or installation.

**Note to Consumer:** Leave this Owner's Manual in a convenient place for future reference.

**Customer Service Helpline:** If you have questions about assembly or grill operation, or if there are damaged or missing parts when you unpack the grill from the shipping box, call us Monday-Friday, 9:00am to 4:30pm, CST, at: 877-508-3866

Thank you for buying a Teton Classic grill. We know that there are many grilling options available. Our unique designs have been developed to combine the best grilling performance with work of art details. We hope that this combination will enable you to join us in an outdoor lifestyle that allows “LIVING AT ITS PEAK”.

## **TABLE OF CONTENTS**

Safety Information	3 - 5
Lighting Precautions	6
Placement of Grill	6
Assembly Instructions	7 - 11
Gas Hook-up	12
Gas Tank Precautions	13 - 14
Leak Testing	14
Operating Instructions	15 - 17
Lighting Instructions	19 - 20
Care and Maintenance	21 - 22
Troubleshooting	23 - 24
Teton Heritage Gas Grill Drawing	26
Teton Heritage Gas Grill Parts List	27
Grilling Hints	28
Limited Warranty	29
Warranty Registration Card	32

## **SAFETY INFORMATION**

### **TO AVOID PERSONAL INJURY**

When properly cared for, your grill will provide safe and reliable service for many years. Abiding by the following safety instructions can greatly reduce the risk of accidents.

- **Do not repair or replace any part of the grill** unless specifically recommended in this manual. **All other service should be referred to a qualified technician.**
- This grill is not intended to be installed in or on recreational vehicles and/or boats.
- **Do not leave the grill unattended while cooking.**
- Do not try lighting this appliance without first reading "LIGHTING INSTRUCTIONS" located on page 14.
- **Your grill will get very hot.** Never lean over the cooking area while using your grill. Do not touch cooking surfaces, grill housing, lid or any other grill parts while the grill is in operation, and until the grill has completely cooled after use.
- Use only dry potholders. Moist or damp potholders on hot surfaces may cause burns from steam. Do not use a towel or bulky cloth in place of potholders. Do not let potholders touch hot portions of the grill rack.
- Do not use aluminum foil to line the grill racks or grill bottom. This can severely inhibit combustion airflow or trap excessive heat in the control area.
- It is recommended that you cover your grill when it is not in use. This prolongs the life of your grill and protects it from the elements.
- **Grease is flammable.** Let hot grease cool before attempting to handle it. Clean the bottom of the grill's firebox often, and do not allow grease deposits to build up.
- For proper lighting and performance of the burners clean the burner ports periodically. The burners will only operate in one position and must be mounted correctly for safe operation.
- **Use caution when cleaning the grill.** Do not use a wet sponge or cloth to clean the grill while it is hot, as this could cause steam burns. Some cleaners produce noxious fumes or can ignite if applied to a hot surface.
- Be sure all grill controls are turned off and the grill is cool before using any type of aerosol cleaner on or around the grill. In the presence of heat, the chemical that causes the spraying action could ignite or cause metal parts to corrode.
- Do not cook excessively fatty meats or products on this grill, or flare-ups may occur.
- Do not operate the grill under overhead combustible construction. **Use only in well ventilated areas.** Do not use in buildings, garages, sheds, breezeways, or other enclosed areas.
- **Keep the area surrounding the grill free from combustible materials,** trash, or combustible fluids and vapors such as gasoline or charcoal lighter fluid.
- **If the unit is stored indoors, make sure it is stored in a cool place.**
- If propane is used, the cylinder must be unhooked and the propane cylinder stored outside in a well ventilated area, out of the reach of children.

## **SAFETY INFORMATION - continued**

- **Do not use briquettes of any kind in the grill.** This grill is designed for use without briquettes. Do not place briquettes on the radiant as this will block of ventilation for the grill burners. Adding briquettes can damage ignition components and knobs, and will void the warranty.
- **Keep the cart clear of debris.** Keep the fuel supply hose away from the heated areas of the grill. Never use the grill in extremely windy conditions. If located in a consistently windy area (oceanfront, mountaintop, etc.) a windbreak will be required. Always adhere to the specified clearance.
- **NEVER USE A DENTED OR RUSTY PROPANE TANK.**
- Children should not be left alone or unattended in an area where the grill is being used. Never allow them to sit, stand, or play on or around the grill at any time.
- Do not store items of interest to children around or below the grill or in the cart. Never allow children to crawl inside of the cart.
- Never let clothing, pot holders, or other flammable materials come into contact with or too close to any grate, burner, or hot surface until it has completely cooled. Fabric may ignite and result in personal injury.
- Wear proper apparel to protect yourself. Loose-fitting garments or sleeves should never be worn while using this appliance. Some synthetic fabrics are highly flammable and should not be worn while cooking.
- Only certain types of glass, heatproof glass ceramic, earthenware, or other glazed utensils are suitable for grill use. These types of materials may break with sudden temperature changes. Use only on low or medium heat settings according to the manufacturer's directions.
- Do not heat unopened food containers as pressure may build up and cause the container to burst.
- Use a covered hand when opened the grill lid. Never lean over an open grill.
- When lighting a burner, always pay close attention to what you are doing. **Be certain you are turning the igniter labeled for the burner you intend on using.**
- Allow grill to cool completely before adding or removing parts.
- Do not operate any outdoor cooking gas appliance after it malfunctions or has been damaged in any manner.
- Do not use an outdoor cooking gas appliance for purposes other than intended.

## **SAFETY INFORMATION - continued**

**Note: LP Gas Cylinder (supplied by others) must be fitted with Overfill Protection Device (OPD).**

**TESTED IN ACCORDANCE WITH ANSI Z21.58A STANDARD FOR OUTDOOR COOKING GAS APPLIANCES. THIS GRILL IS FOR OUTDOOR USE ONLY.**

Check your local building codes for the proper method of installation. In the absence of local codes, use either the National Fuel Gas Code, ANSI Z223.1/NFPA 54. Electrical Code. ANSI/NFPA 70.

- When connecting, first connect plug to the outdoor cooking gas appliance then plug appliance into the outlet.
- Use only a Ground Fault Interrupt (GFI) protected circuit with this outdoor cooking gas appliance.
- Never remove the grounding plug or use with an adapter of 2 prongs.
- Use only extension cords with a 3 prong grounding plug, rated for the power of the equipments, and approved for outdoor use with a W-A marking.

### **! WARNING !**

1. Do not store or use gasoline, other flammable liquids or vapors in the vicinity of this or any other appliance.
2. Do not store a spare LP cylinder in the vicinity of this or any other appliance.
3. Never fill the cylinder beyond 80% full.

**NOTE: If the information above is not followed, a fire causing serious bodily injury, death, or property damage may occur.**

### **! WARNING !**

Combustion byproducts when using **this product contain chemicals known to the State of California** to cause cancer, birth defects, or other reproductive harm.

### **! WARNING !**

Spiders and insects can nest in the grill burners, which causes improper gas flow. This can cause a fire behind and beneath the valve panel, which can damage the grill and make it unsafe to operate. Inspect the grill twice a year.

### **! DANGER !**

**If you smell gas:**

1. Shut off gas to the appliance.
2. Extinguish any open flame.
3. Open lid.
4. If odor continues, keep away from the appliance and immediately call your gas supplier or your fire department

### **Gas Installation Codes**

The installation must conform with local codes or, in the absence of local codes, with the national fuel gas code, ANSIZ223.1/NFPA 54, natural gas and propane installation code, CSA B149.1, or propane storage and handling code, B149.2, as applicable.

## **LIGHTING PRECAUTIONS**

### **! WARNING !**

Always keep your face and body as far away from the burner as possible when lighting.

### **! CAUTION !**

To protect yourself against the risk of electric shock, connect to properly grounded outlets only and keep the extension cord dry and off the ground.

### **BEFORE LIGHTING...**

Inspect the gas supply hose prior to turning the gas "ON". If there is evidence of cuts, abrasion, or wear, it must be replaced prior to use. Do not use the grill if the odor of gas is present. Only the pressure regulator and hose assembly supplied with the unit should be used. Never substitute regulators for those supplied with the grill. If a replacement is necessary, contact the factory for proper replacement.

Screw the regulator onto the tank. Check the hose for leaks and regulator connections with soapy water before operating the grill. If you see bubbling, there is a leak.

Do not attempt to light the grill if the odor of gas is present. Call for service:

877-508-3866

## **PLACEMENT OF GRILL**

### **CLEARANCE**

#### **To Non-Combustible Construction**

#### **MINIMUM CLEARANCE:**

36" Clearance from all sides to combustible material.

### **LOCATION**

When determining a location for your grill, think about several factors that will affect the safe operation of your grill: exposure to wind, proximity to traffic paths, and a short distance to the gas supply. Place the grill in a well-ventilated area. Never place the grill in a building, garage, breezeway, shed or other such enclosed areas. During heavy use, the grill will produce a lot of smoke.

## **ASSEMBLY INSTRUCTIONS**

Assembly of the grill should take 15 to 30 minutes and will require the use of a Phillips screwdriver and one AA battery (not included).

**PLEASE READ THESE INSTRUCTIONS COMPLETELY BEFORE STARTING ANY ASSEMBLY. COMPLETE THIS ASSEMBLY BEFORE INSTALLING ANY LP GAS TANK (supplied by others) TO THE GRILL.**

All screws required for assembly are chrome (silver) and have been set in place where required.

**CAUTION: DO NOT REMOVE ANY BLACK SCREWS DURING THE ASSEMBLY PROCESS. THEY HOLD THE GRILL TOGETHER. ONLY REMOVE CHROME (SILVER) SCREWS WHERE INSTRUCTED.**

### **SIDE BURNER AND SHELF ASSEMBLY**

1. Insert end of burner through the opening in the top of the Side Burner Drip Tray and attach burner assembly to shelf unit with pin.

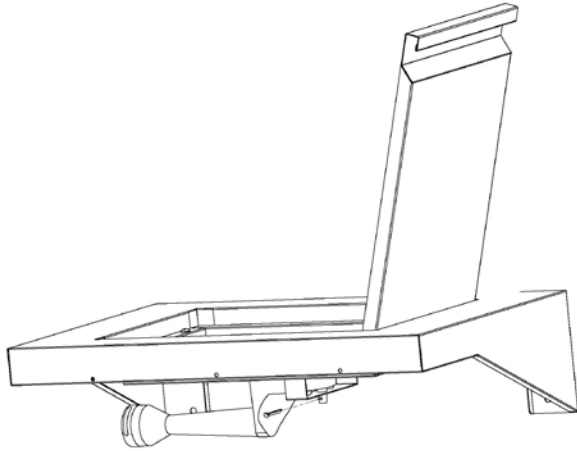

## **ASSEMBLY INSTRUCTIONS- continued**

2. Attach control panel to shelf unit with 2 screws. Insert nozzle at end of gas valve into cast iron burner.

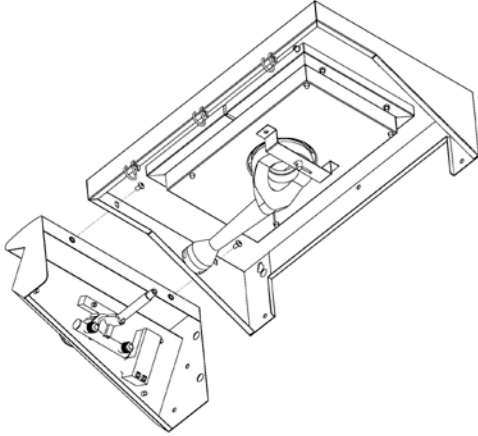

3. Turn over the assembly and attach end of black wire that is fixed to a ceramic piece by the burner to the male attachment clip at top of gas valve on control panel.

4. Attach completed side burner assembly to grill body with 6 screws.

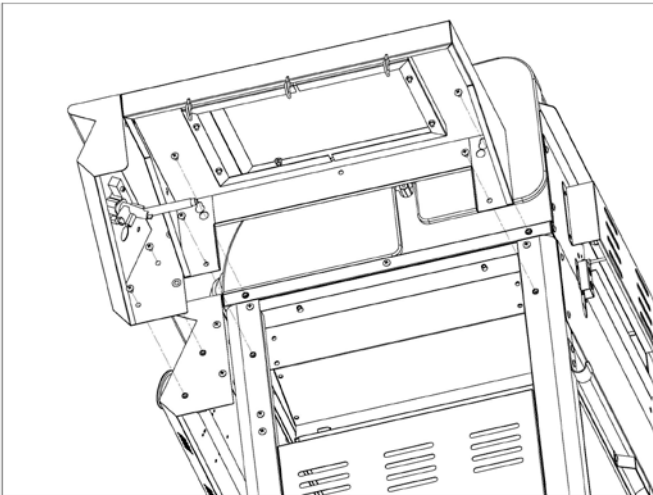

5. Attach wire from rear burner (covered with white insulation) onto the pin on the back side of the Rear Burner Ignitor.

6. Insert AA battery (not supplied) into Rear Battery Ignitor.

## **ASSEMBLY INSTRUCTIONS – continued**

7. Attach hose from main grill burner gas bar to side burner threaded outlet as shown and tighten. Attach hose with regulator to side burner threaded outlet and tighten. Regulator is attached to LP gas tank for use.

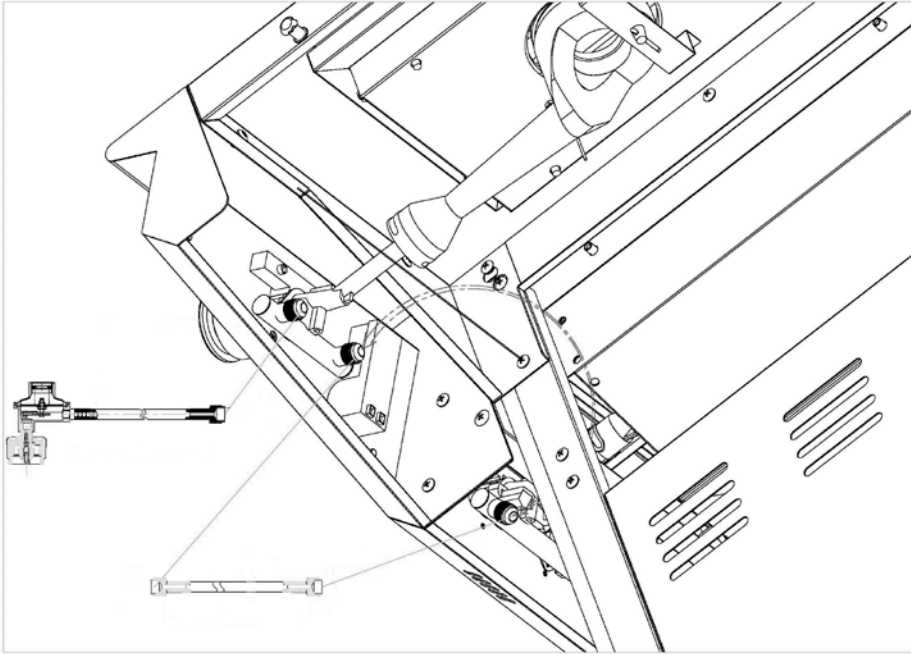

## **WOOD SHELF AND HANDLE ASSEMBLY**

1. Attach Wood Shelf and Handle Assembly to right side of grill cart with seven (7) screws as shown in following drawing.

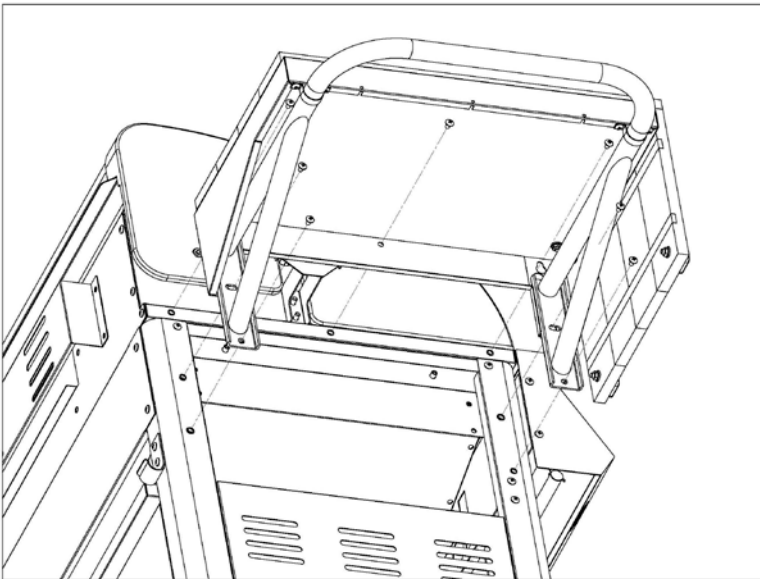

## **DRIP TRAY ASSEMBLY**

1. Insert drip tray collection pan into drip tray as shown below.

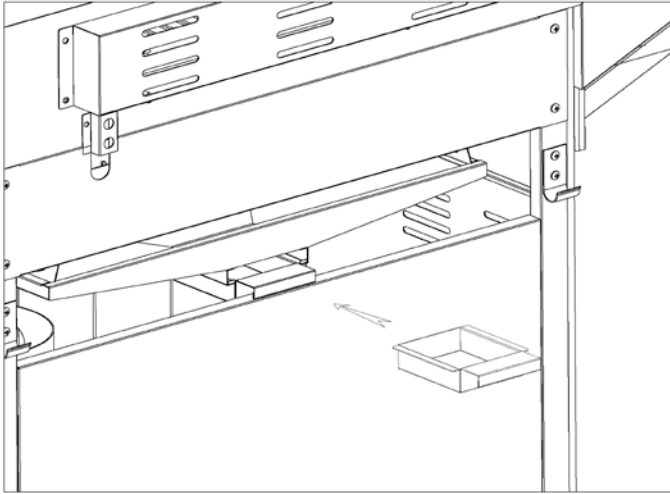

## **GRILL ASSEMBLY**

1. Remove the cast iron Cooking Grates.
2. Install the 4 steel Flame Tamers in the grill, above the burners, as shown in below. Make sure the flame tamers rest securely on the locating pins.
3. Handle the cast iron Cooking Grates with care as they can break if dropped. Place the outside grates in place and slide to the edges of the grill. Place the "finger hole" to the rear of the grill for easier installation. Insert the middle grate.

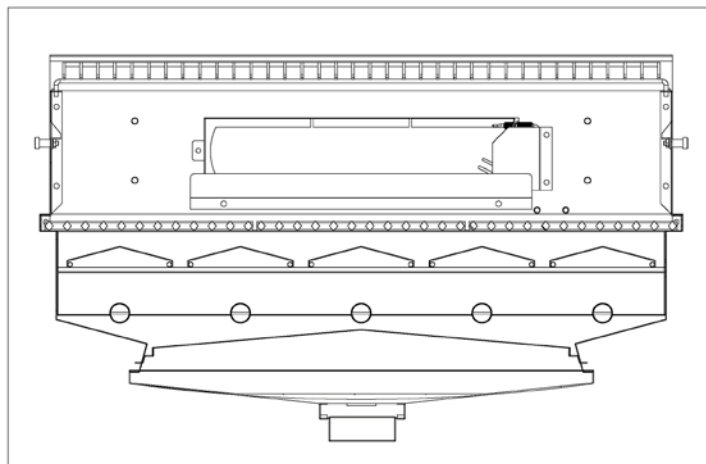

## CONTROL KNOB INSTALLATION

### **BE SURE GAS IS NOT CONNECTED WHEN INSTALLING CONTROL KNOBS**

1. Install the left Control Knob first. Using the supplied 2mm allen wrench, loosen the set screw so that nothing shows on the inside of the stem slot. Put the knob over the left valve stem. Push the knob down and turn 90 degrees to the left.
2. Remove the Control Knob and insert the allen wrench (the long end) into the set screw. Place the Control Knob over the stem and tighten the set screw to secure the knob in place.
3. Turn the Control Knob 90 degrees to the right. The "TG" on the knob should point to **OFF**.
4. Repeat steps 1. thru 3. with the remaining knobs. Work from left to right.

## ROTISSERIE ASSEMBLY

A picture of the rotisserie components follows:

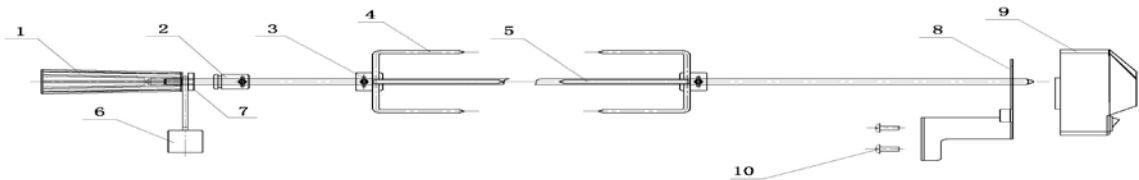

- |                 |                          |
|-----------------|--------------------------|
| 1. Handle       | 6. Counterbalance        |
| 2. Shaft Collar | 7. Washer                |
| 3. Thumbscrew   | 8. Motor Support Bracket |
| 4. Spit Fork    | 9. 110vAC Motor          |
| 5. Spit Rod     | 10. Mount hardware.      |

Mount Motor Support Bracket to left side of grill in holes provided.

Assemble Washer, Counterbalance and Handle to Spit Rod.

Slide Shaft Collar onto Spit Rod with thumbscrew towards handle (do not tighten thumbscrew at this time).

Slide Motor over Motor Support Bracket

Position Spit Rod Assembly onto Grill making sure shaft collar is fully inserted into slot on right Fire Box Support Panel. Slide Spit into Rotisserie Motor until fully inserted. Tighten Thumbscrew on Shaft Collar.

## GAS HOOK-UP

Total gas consumption (per hour) of the Teton Heritage grill with main burners on "IGNITE/HI": 60,000 btu/hr

Side Burner: 12,500 btu/hr

Rear Burner: 10,000 btu/hr

Only the pressure regulator and hose assembly supplied with the grill should be used. Any replacement pressure, regulator and hose assembly must be specified by the grill manufacturer. *This is a liquid propane configured grill.* Do not attempt to use a natural gas supply unless the grill has been converted for natural gas use by the installation of a Natural Gas Conversion Kit installed by a qualified gas plumber.

The installation of this appliance must conform with local codes or, in the absence of local codes, with the national fuel gas code, ANSI Z223.1 Installation in Canada must be in accordance with the Standard CAN/CSA-B149.2 (installation code for gas burning appliances and equipment) and local codes.

### **LP Gas Cylinder Requirements (20lb.Cylinder)**

A dented or rusty LP Gas Cylinder may be hazardous and should be checked by your LP supplier. Never use a cylinder with a damaged valve. The LP gas cylinder must be constructed and marked in accordance with the specifications for LP gas cylinders of the U.S. Department of Transportation (DOT), or the National Standard of Canada, CAN/CSA-B339, Cylinders, Spheres and Tubes for Transportation of Dangerous Goods; and Commission.

The 20lb. cylinder must have a shut off valve connected to a LP gas supply cylinder valve outlet specified, as applicable, for connection type QCC1 is the standard for compressed gas cylinder valve outlet and inlet connection ANSI/CSA-V-1.

LP Gas Cylinder must be fitted with Overfill Protection Device (OPD).

### **LP GAS HOOK-UP:**

Ensure that the black plastic grommets on the LP cylinder valve are in place and that the hose does not come into contact with the grease tray or the grill head.

### **CONNECTION:**

Your grill is equipped with gas supply orifices for use only with liquid propane gas. It is also equipped with a high capacity hose/regulator assembly for connection to a standard 20lb. LP cylinder (approximately 18-1/2" high, 12" diameter).

To connect the LP gas supply cylinder:

1. Make sure tank valve is fully turned off (turn clockwise to stop).
2. Check tank valve to ensure it has proper external male threads (type 1 connection per ANSIZ21.81).
3. Verify all burner valves are turned off.
4. Inspect valve connections, port and regulator assembly. Look for any damage or debris. Remove any debris. Inspect hose for damage. Never attempt to use damaged or obstructed equipment. See your local LP gas dealer for repair.
5. When connecting regulator assembly to the valve, hand-tighten the nut clockwise to a complete stop. Do not use a wrench to tighten. Use of a wrench may damage the quick coupling nut and result in a hazardous condition.
6. Tighten the gas tank retention screw to hold the gas tank in place.

To disconnect LP gas cylinder:

1. Turn the burner valves off.
2. Turn the tank valve off fully (turn clockwise to stop).
3. Detach the regulator assembly from the tank by turning the quick coupling nut counter-clockwise.

## GAS TANK PRECAUTIONS

The maximum size LP tank you should use is approximately 12 inches in diameter by 18-1/2 inches high. **You must use an OPD gas tank which offers an Overfill Prevention Device.** This safety feature prevents the tank from being overfilled, which can cause the LP gas tank, regulator and/or grill to malfunction. The LP gas tank must be constructed and marked in accordance with specifications of the U.S. Dept. of Transportation (DOT). In Canada, the LP gas tank must meet the National Standard of Canada, Can CSA –B339, Cylinders, spheres and Tubes for Transportation of Dangerous Goods and Commission.

1. The LP gas tank must have a shutoff valve that connects to a LP gas supply tank valve outlet, and is compatible with a Type 1 tank connection device. The LP gas tank must also have a safety relief device that is directly connected to the vapor space of the tank.
2. The tank supply system must be arranged for vapor withdraws.
3. The LP gas tank used must have a collar to protect the tank valve.

### **Proper Placement and Clearance of Grill**

**Never** use your gas grill in a garage, porch, shed, breezeway or any other enclosed area. Your gas grill is to be used **outdoors only**, at least 36 inches from the back and side of combustible surfaces. Your gas grill should not be used under overhead combustible construction. Do not obstruct the flow of ventilation air around the gas grill housing. This outdoor gas grill is not intended for use in or on recreational vehicles and/or boats.

Other important precautions:

- **Never** connect an unregulated LP gas tank to your grill. The gas regulator assembly supplied with your grill is adjusted to have an outlet pressure of 11" water column (W.C.) for connection to an LP gas tank.
- Only use the regulator and the hose assembly supplied with your gas grill. Replacement regulators and hose assemblies must be those specified in this manual.
- Have your LP gas tank filled by a reputable propane gas dealer and visually inspected and re-qualified at each filling.
- Do not store a spare LP gas cylinder under or near this appliance.
- Never fill the cylinder past 80% full.
- Always keep LP gas tanks in an upright position.
- Do not store or use gasoline/other flammable vapors and liquids in the vicinity of this gas grill.
- Do not subject the LP gas tank to excessive heat.
- Never store an LP gas tank indoors. If you store your gas grill indoors, **always** disconnect the LP gas tank and store it safely outside.
- Place dust cap on cylinder valve outlet whenever the cylinder is not in use. Only install the type of dust cap that is provided with the cylinder valve. Other types of caps or plugs may result in a propane leakage.
- LP gas tanks must be stored outdoors in a well-ventilated area and out of reach of children. Disconnected LP gas tanks must not be stored in a building, garage or any other enclosed area.
- Turn off the LP gas tank when grill is not in use.
- The regulator and hose assembly must be inspected before each use of the grill. If there is abrasion/wear, or if the hose is cut, it must be replaced prior to use. Call 877-508-3866 for an authorized replacement hose.
- Keep the gas regulator hose away from hot grill surfaces and dripping grease. Avoid unnecessary twisting of hose.

## **! Warning !**

A strong gas smell or the hissing sound of gas indicates a serious problem with your grill or the LP gas tank. Failure to immediately follow the steps below could result in a fire or explosion that could cause serious property damage, personal injury, or death.

If you smell gas or hear the hissing sound of gas:

- Shut off the gas supply to the grill.
- Turn the control knobs to an OFF position.
- Put out any flames with the proper fire extinguisher.
- Open the grill lid.
- Move a safe distance away from the LP gas tank.

**Do not try to fix the problem yourself.** If the odor continues or there is a fire you cannot extinguish, call your fire department. Do not call from near the LP gas tank, as your phone could create a spark and resulting in a fire or explosion

## **LEAK TESTING**

Although all gas connections on the grill are leak tested at the factory prior to shipment, a complete check must be performed at the installation site due to possible mishandling in shipment, or unknown damage to the unit from excessive pressure. Periodically check the whole system for leaks following the procedures listed below. If the smell of gas is detected at anytime, immediately check the entire system for leaks.

- Do not smoke while leak testing.
- Never leak test with an open flame.

**Before testing**, make sure that all packing material is removed from the grill including the burner tie-down straps.

Materials needed:

- Make a soap solution: one part liquid detergent, one part water.
- Spray bottle.
- Brush or rag to apply the solution the fittings.

For the initial leak test, make sure the LP cylinder is full, and the control valves are in the OFF position. Turn the gas supply on. Check all connections from the LP cylinder up to and including the connection to the manifold pipe assembly (the pipe that goes to the burners). Use the soap solution and spray or brush it onto all of the connections.

Soap bubbles will appear where a leak is present. If a leak is present, immediately turn off the gas supply, tighten any leaky fittings, turn the gas on and recheck. If the gas continues to leak from any or all of the fittings, turn off the gas supply, and contact our customer service at 877-508-3866.

Only those parts recommended by the manufacturer should be used on the grill. Substitutions will void the warranty. Do not use the grill until all connections have been checked and do not leak.

# **OPERATING INSTRUCTIONS**

## **General use of the grill**

Each main burner is rated at 12,000 BTU/hr. The main grill burners encompass the entire cooking area and are side ported to minimize blockage from falling grease and debris. Above the burners are steel flame tamers and the igniter knobs are located on the lower center portion of the valve panel. Each rotary igniter is labeled on the control panel.

## **USING THE GRILL:**

Grilling requires high heat for searing and proper browning. Most foods are cooked at the "IGNITE/HI" heat setting for the entire cooking time. However, when grilling large pieces of meat or poultry, it may be necessary to turn the heat to a lower setting after the initial browning. This cooks the food through without burning the outside. Foods cooked for a long time or foods basted with a sugary marinade may need a lower heat setting near the end of the cooking time.

**Important: When cooking with the grill lid closed, never exceed temperatures of 480°F or 250°C.**

## **To begin:**

1. Make sure the grill has been leak tested and is properly located.
2. Remove any remaining packing material.
3. Light the grill burners using the LIGHTING INSTRUCTIONS on the next page.
4. Turn the control knob(s) to "IGNITE/HI" and preheat the grill for a **maximum** of 5 minutes. The grill lid is to be closed during the appliance preheat period.
5. Place the food on the grill and cook to the desired doneness. Adjust heat setting, if necessary. The control knob may be set to any position between "IGNITE/HI" and "LO".

**NOTE:** The grill is designed to grill efficiently without the use of lava rocks or briquettes of any kind. Heat is radiated by the steel flame tamers positioned above each burner.

**NOTE:** The hot grill sears the food, sealing in the juices. The longer your oven preheats, the faster the meat browns and the darker the grill marks.

**NOTE:** Anytime you cook meat above an open flame, you will have flare-ups. Flare-ups, and the resulting smoke, gives a delicious flavor to meat that is cooked over open flames, so expect some flare-up. Excessive flare-ups are due to too high a cooking temperature, or leaving excessive fat on your meat, and can burn your food. To prevent this from happening, trim excess fat from your meat or poultry prior to grilling.

**DO NOT LEAVE THE GRILL UNATTENDED WHILE COOKING.**

## **SHUTTING DOWN YOUR GRILL:**

When you have finished using your grill, turn all knobs to the OFF position. Close the valve on the gas supply.

## **OPERATING INSTRUCTIONS – continued**

### **USING THE ROTISSERIE / REAR BURNER**

A rotisserie is mostly used to cook large pieces of meat or poultry to assure slow, even cooking. The constant turning provides a self basting action, making food cooked on a rotisserie moist and juicy.

### **SAFETY INFORMATION**

When using and electrical appliance, basic safety precautions should always be used, including the following:

1. READ ALL INSTRUCTIONS.
2. Do not touch hot surfaces. Use handles and knobs.
3. To protect against electrical shock, do not immerse cord or plug in water or other liquid.
4. Close supervision is needed when appliance is used by or near children.
5. Unplug from outlet when not in use and before cleaning. Allow to cool before putting on or taking off parts.
6. Do not operate any appliance with a damaged cord or plug, or after the appliance malfunctions or has been damaged in any manner. Take appliance to a qualified repair facility for examination, repair, adjustment or replacement.
7. The use of accessory attachments not recommended by the manufacture may cause injuries.
8. Do not let cord hang over edge of table or counter or touch hot surfaces.
9. Do not place on or near a hot gas or electric burner, or in a heated oven.
10. Extreme caution must be used when moving an appliance containing hot oil or other hot liquids.
11. Always attach plug to appliance first, then plug cord into the wall outlet. To disconnect, turn any control to "OFF", then remove plug from wall outlet.
12. Do not use appliance for other than intended use.
13. The motor is rated for 110/120v, 60Hz AC current.

### **ROTISSERIE COOKING**

Before using the rotisserie and rear burner, the Warming Rack and Cast Iron Cooking Grates should be removed from the grill. It is recommended that a shallow basting pan be placed directly on the flame tamers to catch the drippings while cooking.

For successful operation of the rotisserie, the meat should be centered and balanced as evenly as possible on the spit rod to avoid overworking the motor. After mounting the meat between the 2 spit forks, position the spit rod assembly on the grill and let the heaviest load roll down. Position the counterbalance upwards to counteract the weight. Tighten the Counterbalance by tightening the Handle and Washer. Check to make sure all thumbscrews and other bolts are tightened securely prior to use.

It is important to secure any loose pieces so that when the rotisserie rotates, a part does not become dislodged and catch on the basting pan.

## **OPERATING INSTRUCTIONS – continued**

### **USING ACCESSORY HOLDERS**

Along the right edge of the Side Burner Shelf are three (3) screws with a decorative finish. These screws can be used to hold grilling accessories like a fork, spatula, tongs or a grill brush. Simply unscrew as required to hold the strap on the accessory. Screw back to shelf when not in use.

### **USING SMOKER TRAY**

The enclosed stainless steel smoker tray with cover is designed to be placed directly on the flame tamers.



## **LIGHTING INSTRUCTIONS**

### **! WARNING !**

#### **BEFORE LIGHTING...**

**Do not attempt to light the grill if odor of gas is present.**

Inspect the gas supply hose prior to turning the gas ON. If there is evidence of cuts, wear, or abrasion, it must be replaced prior to use. Do not use the grill if the odor of gas is present. Only the pressure regulator and hose assembly supplied with the unit should be used. Never substitute regulators for those supplied with the grill. If a replacement is necessary, contact the factory for proper replacement.

**If the grill lid is not opened during lighting procedures, there may be a fire or explosion that could cause serious property damage, bodily injury, or death.**

Screw the regulator (type QCC1) onto the tank. Leak check the hose and regulator connections with a soap and water solution before operating the grill

#### **TO LIGHT THE GRILL BURNER:**

Make sure all knobs are OFF; open the grill lid and verify that the end of each burner tube is properly located over each valve orifice. Make sure the gas connections are securely tightened. Open the gas supply from the LP tank slowly until it is half open. Always keep your face and body as far from the grill as possible when lighting.

Your grill is equipped with a pilot flame ignition system on the burners. Push the Control Knob in and turn slowly (counterclockwise) to HI. If you have difficulty lighting the burner, it may be necessary to turn and hold the knob for 1 second before it “clicks”. If the burner does not light, try once more. If it still does not ignite, wait 5 minutes for any accumulated gas to dissipate, and then retry.

Adjust the knobs to your desired cooking temperature. The lowest flame setting will occur when the knob is turned fully counterclockwise.

#### **TO LIGHT THE GRILL BY MATCH:**

To light your gas grill by match, open the lid and light a match. Place the lit match on the match holder as shown in Figure A. Turn the right main burner control knob to the HI setting to release the gas while holding the lit match on the match holder, located near the main burner. The burner should light within 5 seconds. If it fails to light, turn the valve off and wait 5 minutes before attempting to manually light the burner again.

#### **TO LIGHT SIDE BURNER**

To light the side burner, remove any cooking utensils from the burner grate. The Side Burner utilizes the same ignition system as the grill burners. Please use the same procedure described above in “TO LIGHT THE GRILL BURNER” for the Side Burner. If it is necessary to utilize a match to light the Side Burner, utilize instructions “TO LIGHT THE GRILL BY MATCH” above.

#### **TO LIGHT REAR BURNER**

**Open the lid. Before lighting Rear Burner, remove Warming Rack as heat from rear burner may damage it.** Turn the Rear Burner control knob to HI. While holding in the knob, push the Electronic Rear Burner Ignitor to light the Rear Burner. Once the Rear Burner is lit, continue to hold in for another 15 seconds to be sure the burner stay lit. If the burner does not light, turn the Control Knob to “OFF”. If the ignitor does not function, follow the instruction above for match lighting

**WARNING: ALWAYS KEEP YOUR FACE AND BODY AS FAR FROM BURNERS AS POSSIBLE WHEN LIGHTING.**

## **LIGHTING INSTRUCTIONS - continued**

### **FLAME CHARACTERISTICS**

Check for proper flame height. Each burner is adjusted prior to shipment; however, variations in the local gas supply may take minor adjustments necessary.

Burner flames should be next to the burner, blue and stable with no yellow tips, excessive noise, or lifting.

Visually check the burner flames prior to each use. On high, the flames should be about 1 inch tall and over 80% of the flame should be blue in color.

If the burner is not getting enough air, the flame will be mostly red or it may make a popping sound. If the burner is getting too much air, the flames will be far off the burner.

If necessary to adjust the air to the burner, remove the burner when it is cool. At the open end of the burner is a shutter that is held in place by one screw. Adjust this shutter accordingly to allow more or less air as required and then reinstall the burner.

## **CARE AND MAINTENANCE**

### **Stainless Steel**

Many of the grill components are made with non-rusting and non-magnetic stainless steel. There are many different stainless steel cleaners available. **Always use the most mild cleaning procedure first. Always clean by scrubbing in the direction of the grain.** To touch up scratches, sand very softly with dry 400-grit sand paper in the direction of the grain. Specks of grease can accumulate on stainless steel surfaces and appear to be rust. To remove these spots, use an "Scotch-Brite" pad and stainless steel cleaner; this will remove most stains. Remember to rub in the direction of the grain.

### **Grill Rack**

It is easiest and best to clean your grill immediately after cooking and turning off the flame. Wear a barbecue mitt to protect your hand from heat and steam. Dip a brass bristle brush in tap water and scrub the hot grill. Steam assists the cleaning process by softening any food particles that are stuck to the rack. The food particles will fall and burn. If you clean your grill after it cools, it will be more difficult.

### **Grill Burners**

Extreme care should be taken when moving a burner, as it must be correctly re-centered in its place before any attempt is made to relight the grill. Frequency of cleaning will depend on how often you use the grill.

### **Grill Burner Cleaning**

Ensure the gas supply is off and the knobs are in the OFF position. Make sure the grill is cool. Clean the exterior of the burner with a wire brush. Clear stubborn stains with a metal scraper. Clear any clogged ports with a straightened paper clip. Never use a wooden toothpick as it may break off and clog the port. Please note if insects or other obstructions are blocking the flow of gas through the burner

### **Drip Tray Cleaning**

The drip tray should be emptied and wiped down periodically and washed in a mild detergent and warm water solution. A small amount of sand or cat litter may be placed in bottom of drip tray to absorb grease. Check the grease tray frequently; don't allow excess grease to accumulate and overflow out of the drip tray.

### **Other Surfaces**

Clean all other surfaces with mild detergent and warm water. Avoid scratching any surfaces.

## **Check your grill for the following items twice a year:**

1. Make sure the area around the grill is free and clear of combustible materials.
2. Make sure the combustion and ventilation openings are not obstructed.
3. Make sure the ventilation openings of the cart are not obstructed.
4. Visually check the burner flames and verify the flame height on high is approximately 1 inch high and 80% or more of the flame is blue in color.
5. Clean your grill as described above.
6. Check your grill for spiders and insects as described on Page 22.

## **CARE AND MAINTENANCE- continued**

### **HOW TO REPLACE THE MAIN BURNER**

1. Remove the burner by removing the one hold down screw and lifting burner out.

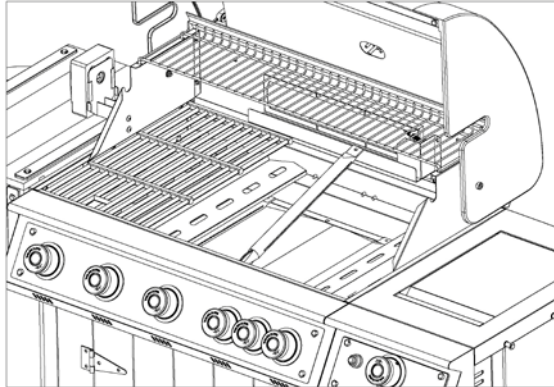

2. Examine the open end of the new burner. There is a shutter around the outside of the open end held in place with one screw that controls the air used by the burner. Loosen this screw and make the opening the same size as the burner removed. Then tighten the screw.
3. Set new burner in place. Be sure that the open end of the burner is centered over the gas orifice. The orifice should extend into the open end of the burner about 1/16" to 1/8". This can be viewed by looking under the control panel.
4. Secure the burner onto the firebox with the reinstallation of one screw.

## **IMPORTANT NOTE**

### **Spiders and Insects**

Spiders and insects can nest in the burners of the grill and cause the gas to flow from the front of the burner. This is a very dangerous condition, which can cause a fire to occur behind the valve panel, thereby damaging the grill and making it unsafe to operate.

You should inspect the burners at least twice a year or immediately after any of the following conditions occur:

1. If the burner flames appear yellow and you smell gas.
2. If the grill does not reach the correct temperature.
3. If the grill heats unevenly.
4. If the burners make popping noises.

**Before calling for service**, use the following checklist to identify your problem. This may save the cost of a service call.

## TROUBLESHOOTING

A list of common problems and solutions is located on the proceeding pages.

PROBLEM	SOLUTION
<b>When I light the grill it does not immediately ignite.</b>	<ul style="list-style-type: none"><li>-- Make sure the gas is turned ON.</li><li>-- Make sure there is a spark while trying to ignite the burner.</li><li>-- Push in and hold for approximately 5 seconds before turning the knob.</li><li>-- Make sure your burner is clean.</li></ul>
<b>The regulator makes noise.</b>	<ul style="list-style-type: none"><li>-- The vent hose on the regulator may be plugged, or the regulator may be faulty.</li><li>-- Ensure the vent hole on the regulator is not obstructed. If obstructed, clear the hole, and close the LP tank and gas control valves. Wait ten minutes and re-start.</li><li>-- When turning on the LP tank valve, do not cover the vent hole on the regulator.</li><li>-- Check the flames for proper performance; if the flames are incorrect, replace the regulator.</li></ul>
<b>The grill only heats to 200°F - 300°F.</b>	<ul style="list-style-type: none"><li>-- Ensure the temperature gauge is functioning properly. Hold a flame to the probe or compare the grill gauge to an oven thermometer placed in the grill.</li><li>-- Ensure correct start procedure. Prior to lighting the grill, the gas control knobs should be OFF. The propane bottle should be OFF. If not, wait 15 minutes. Turn the tank all completely ON. Turn the left burner to ignite, wait 5 seconds, and ignite. Repeat for additional burners.</li><li>-- Check all gas connections for leaks with a soap-water bubble test. If leaks are found, replace the part or tighten the fitting.</li></ul>

<p><b>The grill takes a long time to preheat.</b></p>	<ul style="list-style-type: none"> <li>-- It normally takes about 10 minutes in order for your grill to reach a pre-heating temperature of <b>480°F</b>. Cold weather and wind may effect your preheat time.</li> <li>-- If you are using volcanic rock or briquettes, it can increase the preheat time and maximum temperature. Remember that briquettes should NOT be used on this appliance.</li> </ul>
<p><b>The burner flames are not light blue.</b></p>	<ul style="list-style-type: none"> <li>-- There is too much or not enough air to fuel the flame.</li> <li>-- Elevation is most commonly the cause of this problem; cold weather is also a common cause. Burner adjustments may be required. Please refer to the manual for adjustment procedures.</li> <li>-- The grill may be in too windy of a location.</li> </ul>



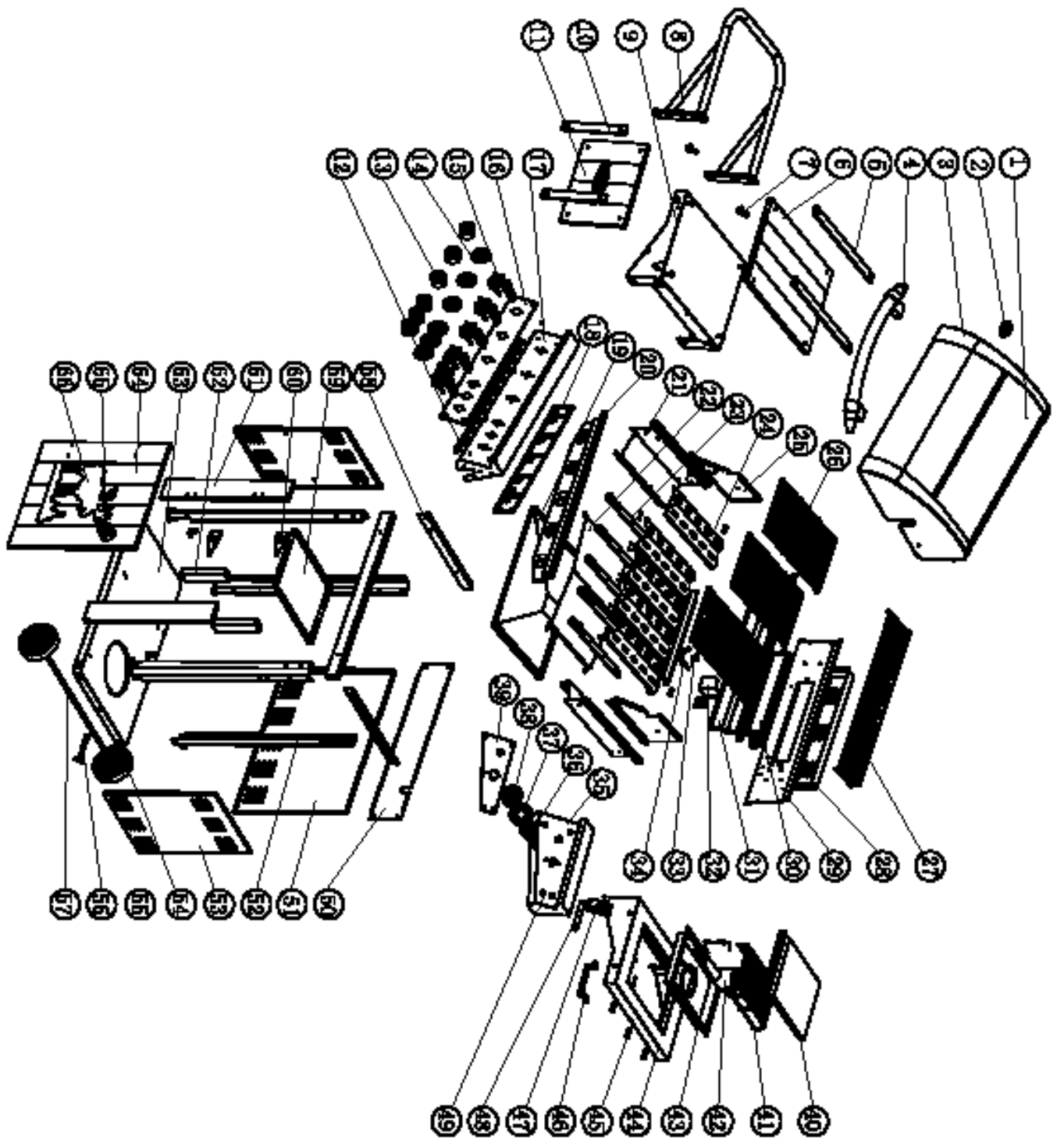

**Teton Heritage Gas Grill Parts List**

<b>Item</b>	<b>Description</b>	<b>Qty</b>
1	Lid	1
2	Thermometer	1
3	Side Panel for Lid	2
4	Handle	1
5	Accent Panel for Side Shelf	2
6	Side Shelf Wooden Table	1
7	Side Shelf Handle Support	2
8	Side Shelf Handle	1
9	Side Shelf	1
10	Accent Panel for Side Shelf	2
11	Side Shelf Wooden Logo	1
12	Manifold	1
13	Control Knob	6
14	Bezel	6
15	Valves	6
16	Accent for Control Panel	1
17	Control Panel	1
18	Control Panel Liner	1
19	Drip Tray	1
20	Fire Box Front Panel	1
21	Fire Box Side Panel	2
22	Drip Tray Support Panel	1
23	Burner	5
24	Flame Tamer	5
25	Fire Box Support Panel	2
26	Cooking Grate	3
27	Warming Rack	1
28	Rear Burner Back Panel	1
29	Rear Burner Support Panel	1
30	Rear Burner	1
31	Fire Box Back Panel	1
32	Rear Burner Ignition Cover Panel	1
33	Thermocouple	1

<b>Item</b>	<b>Description</b>	<b>Qty</b>
34	Rear Burner Ignition	1
35	Side Burner Control Panel	1
36	Side Burner Valve	1
37	Side Burner Bezel	1
38	Side Burner Control Knob	1
39	Accent for Side Burner Control Panel	1
40	Side Burner Cover	1
41	Side Burner Cooking Grate	1
42	Side Burner	1
43	Side Burner Drip Tray	1
44	Side Burner Support Panel	1
45	Screws to Hold Accessories	3
46	Side Burner Support	1
47	Electronic Rear Burner Ignitor	1
48	Side Burner Manifold	1
49	Accent Panel Screw	4
50	Fire Box Cover Panel	1
51	Cart Back Panel	1
52	Cart Legs	4
53	Cart Side Panel	2
54	Wheel	2
56	Gas Tank Retention Screw	1
57	Wheel Axle	1
58	Cart Side Cover Panel	2
59	Cart Shelf	1
60	Hinge	2
61	Wooden Door Support Panel	2
62	Cart Shelf Support	2
63	Cart Bottom Panel	1
64	Wooden Cart Door	1
65	Wood Door Knob	1
66	Door Accent Piece	1

## GRILLING HINTS

The doneness of meat, whether rare, medium, or well done, is affected to a large degree by the thickness of the cut. Expert chefs say it is impossible to cook rare a thin cut of meat.

The cooking time is affected by the kind of meat, the size and shape of the cut, the temperature of the meat when cooking begins, and the degree of doneness desired.

When defrosting meats, it is recommended that it be done overnight in the refrigerator as opposed to a microwave. This in general yields a juicier cut of meat. Do not thaw at room temperature.

Use a spatula instead of tongs or a fork to turn the meat, as a spatula will not puncture the meat and the juices will be retained instead of running out.

To get the juiciest meat, season or add salt after the cooking is finished on each side and turn the meat only once (juices are lost when the meat is turned several times). Turn the meat just after the juices begin to bubble to the surface.

Trim any excess fat from the meat before cooking. To prevent steaks or chops from curling during cooking, slit the fat around the edges at 2-inch intervals.

***DO NOT LEAVE THE GRILL UNATTENDED WHILE COOKING.***

## LIMITED WARRANTY

Teton Grill Company hereby warrants to the ORIGINAL PURCHASER of this Teton Grill Company Gas Barbeque Grill that, when assembled and operated in accordance with the printed instructions that accompany it, it will be free of defects in material and workmanship from the date of purchase as follows:

<b>Component</b>	<b>Warranty Period</b>
Stainless Steel Burners and Cooking Grids:	3 years
All Stainless Steel Exterior Parts:	2 years
Flame Tamers, Igniter Assemblies, and All Remaining Parts:	2 years

High cooking temperatures, excessive humidity, chlorine, fertilizers, lawn pesticides and salt can affect Stainless Steel components and for these reasons, the limited warranties DO NOT COVER DISCOLORATION OR RUST, unless there is a loss of structural integrity on the grill component.

Teton Grill Company shall not be liable under this or any implied warranty for incidental or consequential damages and Teton Grill Company's liability is limited to the purchase of this barbeque. This warranty gives you specific legal rights, and you may also have other rights which vary from state to state. This warranty is applicable in the United States and Canada. No one else is authorized to perform any obligations under this warranty.

Teton Grill Company requires reasonable proof of your date of purchase. THEREFORE YOU SHOULD RETAIN YOUR SALES SLIP OR INVOICE AND RETURN THE TETON GRILL COMPANY PRODUCT REGISTRATION CARD IMMEDIATELY.

This limited warranty shall be limited to the repair or replacement of parts which prove defective under normal use and service and which on examination shall indicate to Teton Grill Company's satisfaction they are defective. Before returning any parts to Teton Grill Company, contact our **Customer Service Center at (877) 508-3866** or email us at [contact@tetongrills.com](mailto:contact@tetongrills.com).

If Teton Grill Company confirms the defect and approves the claim, then Teton Grill Company will elect to replace such part without charge. Parts returned to Teton Grill Company must be sent freight prepaid to Teton Grill Company, Customer Service Department, 3880 4<sup>th</sup> Avenue East, Shakopee, MN, 55379. Teton Grill Company will return parts to the purchaser freight or postage prepaid.

The LP tank manufacturer is solely responsible for the materials, workmanship and performance of the tank. If the tank has a defect, malfunctions, or if you have questions regarding the tank, call the tank manufacturer's customer service center. The phone number is on the warning decal, which is permanently attached to the tank.

MODEL NUMBER: \_\_\_\_\_  
SERIAL NUMBER: \_\_\_\_\_  
DATE PURCHASED: \_\_\_\_\_  
PURCHASED FROM: \_\_\_\_\_

### WARRANTY RESTRICTIONS

**Converting these barbecues to Natural Gas can be done provided the appropriate NG Conversion Kit is used and is done by a licensed technician. Failure to follow these instructions will void the warranty and is also extremely dangerous and could cause fire or injury.**

This warranty is void if grill is used for commercial or rental purposes.

This warranty applies only when the grill is used in the United States and Canada.

This warranty gives you specific legal rights; you may also have other legal rights that vary from state to state.

Teton Grill Company – 3880 Fourth Avenue East – Shakopee, MN 55379





